

**ROCK RAKE**



**EQUIPMENT BUILT  
TO LAST**



[www.shoule.com](http://www.shoule.com)

# SWD-15 MODEL

# FIERGE



Like all Houle products, our Rock Rakes are built to last, and will handle a variety of tasks:

- windrowing rocks for easier picking
- windrowing excess dirt or gravel to be used elsewhere
- preparation of fields for sowing

Our Rock Rakes are built with durability and functionality in mind. Here are some of their best features:



## SWD-15

**Transportation mode is achieved using hydraulic cylinders**

- The gearbox is totally enclosed to reduce exposure of the internal components to dust (chain, gears, and bearings). The slip clutch is covered for **BETTER PROTECTION**.
- The SWD-15 is equipped with three 11L/15 tires.
- The teeth are cut from RT-400 steel, which is 4 times **MORE RESISTANT** than regular steel, and are reversible and replaceable.
- The height adjustment mechanism is equipped with a cylinder (3 in / 8 cm diam. and 8 in / 20 cm stroke) that allows you to raise or lower the rake. The other cylinder allows you to position the rake for work or travel.

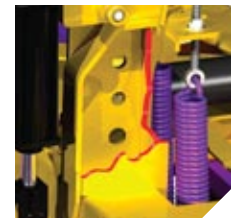

- The SWD-15 rock rake is equipped with several guards and shields to prevent rocks from being ejected from the rake and to protect the rake from damage.
- The SWD-15 rock rake is also equipped with a flotation system.

Model	Steel frame	Weight	Recommended HP	PTO
SWD-15	6 x 13 ft / 1.8 x 4 m	4,700 lbs / 2,132 kg	65 HP (48 kW) and +	540 RPM

**The SWD-15 can be attached to ANY MODEL of tractor, thanks to its universal hitch.**

# SRR-15 MODEL

# DURA

# BLEE



## SRR-15

### Transportation mode is achieved manually

- The gearbox is hermetically sealed to **REDUCE EXPOSURE** of the internal components to dust (chain, gears, and bearings). The slip clutch is covered for better protection.
- The SRR-15 is equipped with two 11L/15 tires.
- The teeth are cut from **RT-400 STEEL**, which is 4 times more resistant than regular steel, and are reversible and replaceable.

- The height adjustment mechanism is equipped with a cylinder (3 in / 8 cm diam. and 6 in / 15 cm stroke) that allows you to raise or lower the rake. The other cylinder (3 in / 8 cm diam. and 8 in / 20 cm stroke) allows you to place the tow bar in transport position (the wheels must be placed in transport position manually).

- The SRR-15 rock rake is equipped with **SEVERAL GUARDS AND SHIELDS** to prevent rocks from being ejected from the rake, and to protect the rake from damage.
- In travel position, the SRR-15 occupies a width of less than 8 feet (2.43 m).
- The SRR-15 is also equipped with a flotation system.

Model	Steel frame	Weight	Recommended HP	PTO
SRR-15	6 x 13 ft / 1.8 x 4 m	3,850 lbs / 1,746 kg	65 HP (48 kW) and +	540 RPM

# PWD-10 MODEL



## PWD-10

The PWD-10 rock rake is a smaller version of the SWD-15 and SRR-15 models - small, but still a pull type rake, it offers you the versatility you need in smaller areas. The major advantage to this rake is that it can tilt from side to side, allowing you to better control how the dirt is deposited, and finish with neat rock windrows for easier picking.

- The gearbox is **HERMETICALLY SEALED** to reduce exposure of the internal components to dust (chain, gears, and bearings). The slip clutch is covered for better protection.
- The PWD-10 is equipped with two 11L/15 tires.
- The teeth are cut from RT-400 steel, which is 4 times **MORE RESISTANT** than regular steel, and are reversible and replaceable.
- The pivot assembly cylinder (3 in / 8 cm diam. and 8 in / 20 cm stroke) allows for a maximum **VERTICAL MOVEMENT** of 22 in (56 cm).
- The cylinder (3 in / 8 cm diam. and 6 in / 15 cm stroke) allows the left wheel to be lowered by over 6 in (15 cm), enabling an **INCLINATION** of up to 5 degrees.



## EASY MAINTENANCE



Model	Steel frame	Weight	Recommended HP	PTO
PWD-10	4 x 6 ft / 1.22 x 1.82 m	2,350 lbs / 1,066 kg	65 to 125 HP (48 to 93 kW)	540 RPM

EQUIPMENT BUILT TO LAST

# WD-6 MODEL WD-10B MODEL

RELIABLE

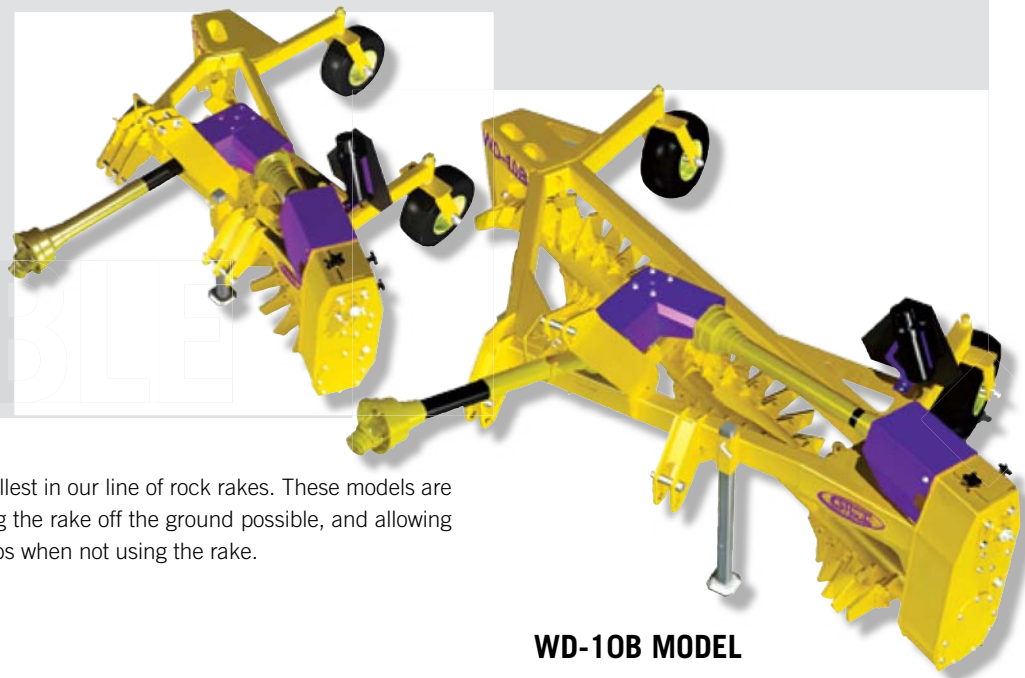

The WD-10B and WD-6 models are the smallest in our line of rock rakes. These models are equipped with a 3 point hitch making raising the rake off the ground possible, and allowing the operator to focus completely on other jobs when not using the rake.

## WD-6 MODEL



### WD-6

- The WD-6 is equipped with 16.5 x 6.5 tires that are designed to pivot 360°, allowing for great **MANEUVERING FLEXIBILITY**.
- The WD-6 comes with a three-point hitch appropriate for 40 to 65 HP tractors.

### WD-10B

- The WD-10B is equipped with 18.5 x 8.5 tires that are designed to **PIVOT** 360°, allowing for great maneuvering flexibility.
- The WD-10B comes with a three-point hitch (No. 2) appropriate for 65 to 125 HP tractors.

### COMMON FEATURES

- The gearbox is hermetically sealed to reduce exposure of the internal components to dust (chain, gears, and bearings). The slip clutch is covered for **BETTER PROTECTION**.
- The teeth are cut from RT-400 steel, which is 4 times more resistant than regular steel, and are **REVERSIBLE AND REPLACEABLE**.

## WD-10B MODEL



Model	Steel frame	Weight	Recommended HP	PTO
<b>WD-6</b>				
WD-6	2 x 5 ft / 0.6 x 1.5 m	1,120 lbs / 508 kg	40 to 65 HP (30 to 48 kW)	540 RPM
<b>WD-10B</b>				
WD-10B	3 x 5 ft / 0.9 x 1.5 m	1,850 lbs / 840 kg	65 to 125 HP (48 to 93 kW)	540 RPM

**TO LEARN MORE ABOUT OUR PRODUCTS:  
DIAL 1 888 404-4380 OR VISIT [WWW.SHOULE.COM](http://WWW.SHOULE.COM)**



## WE ARE ACCESSIBLE WORLDWIDE

Why do our rock rakes offer you the performance you need for heavy work?

- **BECAUSE WE'RE AT THE HEART OF THE FARMING COMMUNITY**, we know your needs.
- Our products are **CONSTANTLY TESTED**.
- Their design allows **GREAT MANEUVERING FLEXIBILITY**.
- Their **HEAVY DUTY** construction lets you save on time and manpower.

As part of our commitment to continual improvement of our products, we reserve the right to modify the products presented in this brochure without notice.



**1 YEAR**  
**WARRANTY**  
PARTS AND LABOR

**FAST**  
**DELIVERY** 



### Fabrication S. Houle inc.

300 Industriel Blvd., P.O. Box 750, Saint-Germain (Quebec) CANADA J0C 1K0  
Tel.: 819 395-4380 • Toll free: 1 888 404-4380 • Fax: 819 395-5516  
E-mail: info@shoule.com

[www.shoule.com](http://www.shoule.com)

